

Contents

Safe Usage	1
■ Valve Packings	2 ~ 16
■ Packing Recommendations - For valves	2 ~ 3
■ Selection Guide	4 ~ 5
■ Valve Packings	6 ~ 16
■ Selection Guidelines for High Temperature Use Packings	10 ~ 11
■ Rotary Shaft Packings	17 ~ 27
■ Packing Recommendations - Rotary Shaft Packings	17
■ Rotary Shaft Packings	18 ~ 27
■ Other Packings	28 ~ 36
Numerical Index	37

* Names with a TM symbol are trademarks of NICHIAS Corporation.

* "TOMBO" is a registered trademark or trademark of NICHIAS Corporation.

Safe Usage

Please observe the following in order to obtain the full function of the products and to ensure safe usage.

CAUTIONS

Properties/applications shown throughout this catalogue are typical.

Performance data referred to in this catalog are based on our own test results and on performance in general applications under normal conditions.

Products listed in this catalogue are used in diverse locations and for numerous types of machinery and equipment, and actual conditions of use also differ extensively. Consequently, when using these products, we recommend that you implement verification tests under the actual conditions of use.

Regarding individual applications, it is necessary to make a selection decision based on individual designs and on suitability evaluations. For special applications, please consult us.

The contents of this catalog are subject to change without prior notice.

1. Never use for any purpose other than the prescribed application.
2. When processing, use sharp cutting tools.
3. Always follow the instructions in this catalog or the instruction manual when installing equipment, etc.
4. Do not re-use packings.
5. When replacing, carefully remove all of the old material before installing the new product.
6. To maintain performance, store packaged products in a cool and dark place.
7. Please refer to SDS (Safety Data Sheet) concerning health and hygiene cautions.
8. When disposing, comply with all regulations in your country. Waste should be properly disposed of at a permitted disposal site. Do not incinerate the used products, especially those containing fluoropolymer resin as it will generate toxic gas when burning.

Packing Recommendations - For valves

Fluid	Operating conditions		Recommended Packing (TOMBO No.)	Remarks
	Temperature (°C)	Pressure MPa		
Steam	600	18	2205P+2250-A	
		7	2280-S	
Hot water	500	24	2205P+2250-A	
		8	2280-S	
Water	350	34	2205P+2250-A	
		12	2280-S	
Salt water (Brine)	260	39	2205P+2250-A	
		14	2280-S	
	100	44	2205P+2250-A	
		16	2280-S	
Petroleum-based hydrocarbons Gasoline Naphtha Kerosene Light oil Heavy oil Lubricating oil Oil gas Alcohol Animal and vegetable oils	600	18	2205P+2250-A	
		7	2280-S	
	500	24	2205P+2250-A	
		8	2280-S	
	350	34	2205P+2250-A	
		12	2280-S	
	260	39	2205P+2250-A	
		14	2280-S	
	150	43	2205P+2250-A	
		15	2280-S	
Aromatics-based hydrocarbons Benzene Toluene Xylene Cyclohexane Organic solutions Heat transfer solutions	600	18	2205P+2250-A	
		7	2280-S	
	500	24	2205P+2250-A	
		8	2280-S	
	350	34	2205P+2250-A	
		12	2280-S	
	260	39	2205P+2250-A	
		14	2280-S	
	150	43	2205P+2250-A	
		15	2280-S	
Weak acid	300	13	2205P+2250-A	
		4	9077	
Weak alkali Salt solutions	260	14	2205P+2250-A	
		5	9034	
		5	9077	

Selection Guide

Water type fluids / Oil type fluids

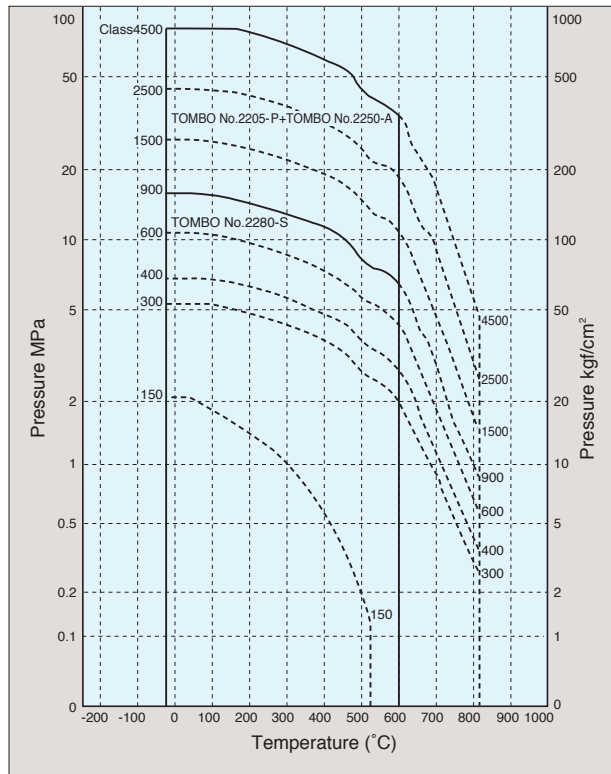

Water type fluids

Fresh water, Brine, Industrial water, Hot water, Boiler feed water, Saturated steam, Superheated steam, Drain, Neutral salt solutions (Sodium chloride, Calcium chloride, Sodium nitrate, Sodium Sulfate, etc.)

Oil type fluids

Crude oil, Naphtha, Gasoline, Heavy oil, Light oil, Kerosene, Fuel oil, Lubricant, Animal and vegetable oil, General mineral oil, Oil gas, Heat transfer oil (other than molten salts)

Corrosive fluids (except strong oxidizing acids) / Solvents

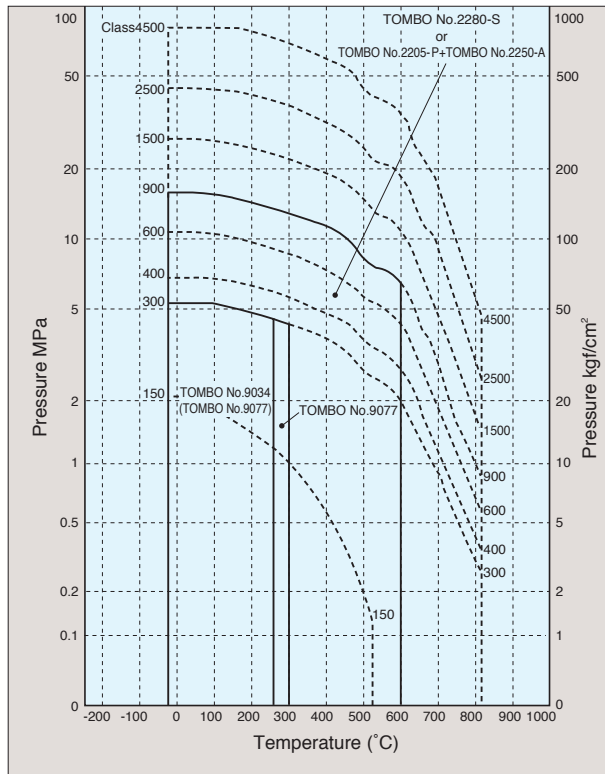

Corrosive fluids (except strong oxidizing acids)

Hydrochloric acid, Organic acids (Acetic acid, Citric acid, Phthalic acid, Lactic acid, etc.), Alkali (Sodium hydroxide, Potassium hydroxide)

Solvents

Aromatic hydrocarbons (Benzene, Toluene, Xylene), Alcohol, Ketone, Amines, Ether

Corrosive fluids (Strong oxidizing acids)

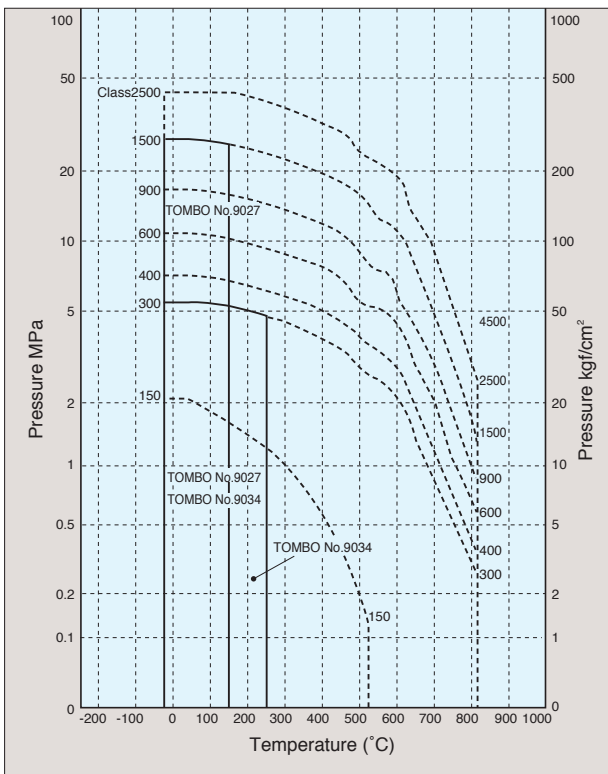

- **Corrosive fluids (Strong oxidizing acids)**
 Oxidizing acids (Nitric acid, Concentrated sulphuric acid, Chromic acid, Mixed acid, etc.)
 Oxidizing salts (Nitrate, Chlorate, Hypochlorite, etc.)

Gas type fluids

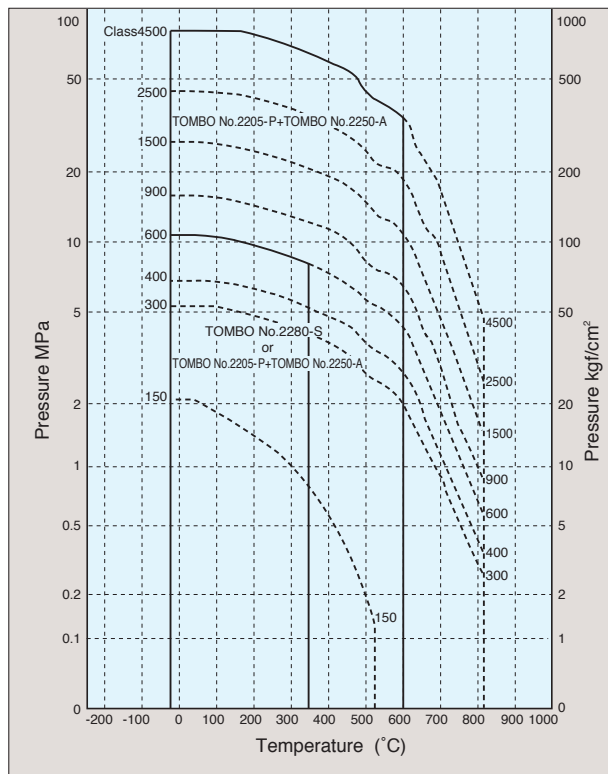

- **Gas type fluids**
 Incombustible gases (Carbon dioxide, Nitrogen, etc.), Air, Exhaust gas, Combustible gases (Methane, Ethane, Propane, Butane, Ethylene, Hydrogen, Acetylene, Propylene, Butylene, etc.)

Cryogenic fluids

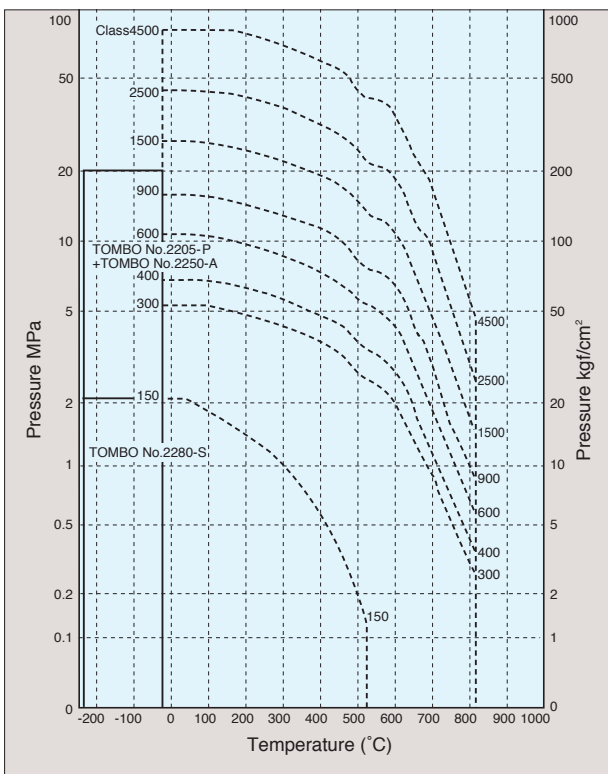

- **Cryogenic fluids**
 LNG, LPG, LN₂, Ethylene, etc.

Supporting gases

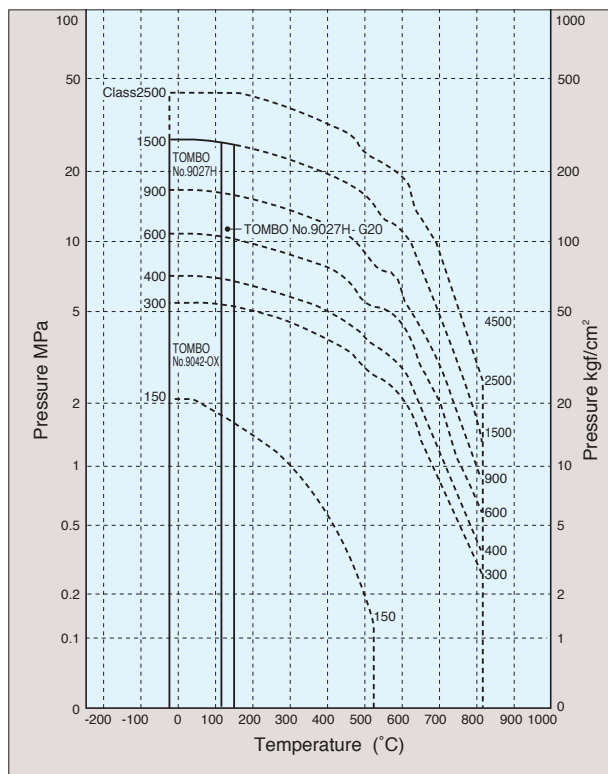

- **Supporting gases**
 Oxygen, Ozone

High Temperature Use Packings

GRASEAL™ Packing

TOMBO™ No.2200 and 2205 Series

Construction

TOMBO No.2200 series is a packing made from expanded graphite (GRASEAL) cut into strips and shaped into rings in a mold. The packing is treated to give it anti-corrosion features, and is an excellent packing for high temperature / high pressure applications.

We carry TOMBO No.2200-P and TOMBO No.2200-L models of this packing, each having different types of impregnated lubricant.

The TOMBO No.2205 series is a TOMBO No.2200 packing with the addition of a stainless steel mesh incorporated into its center so that the packing can be removed easily. Like the TOMBO No.2200 series, we carry TOMBO No.2205-P and TOMBO No.2205-L models.

45 degree bias cut is standard but non-cutting or 2 cutting are also available on request.

Features

1. Superior sealing performance compared to asbestos products.
2. Little differences in performance from cryogenic to high temperatures.
3. Expanded graphite (GRASEAL) has chemical resistance properties second only to PTFE, and can be used with almost any fluid (with the exception of those listed below).
4. Less shrinkage at high temperatures than asbestos packings, with little stress relaxation.

Service Range

Temperature range	– 240 ~ 400°C (oxidizing atmosphere, in air) – 240 ~ 1650°C (non-oxidizing atmosphere)
Max. Pressure	78MPa (when used with a TOMBO No.2250-A or other adapter packing)
Pressure Class	4500

Application

Thermal power plants, petroleum refineries, shipbuilding, chemical plants, cryogenic services, high temperature gas plants, etc.

Cast steel valves, forged steel valves, stainless steel valves, etc.

Fluids

Water type fluids (water, hot water, steam, etc.), oil type fluids (oil, heat transfer oil, etc.), organic solvents, hydrocarbons, gaseous fluids (hydrogen, ammonia, etc.), chemical products, corrosive fluids (other than oxidizing fluids), and cryogenic fluids (LN₂, liquid air, LNG, LPG, etc.).

⚠ Not applicable

Type	Fluid name
Oxidizing acids	Nitric acid, concentrated sulphuric acid, hot sulphuric acid, mixed acids, chromic acid, etc.
Oxidizing salts	Nitrate, chlorate, hypochlorite, etc.
Halogen compounds	Bromine, fluorine, iodine, chlorine dioxide, etc.
Combustion promoting gas	Oxygen (pure oxygen)

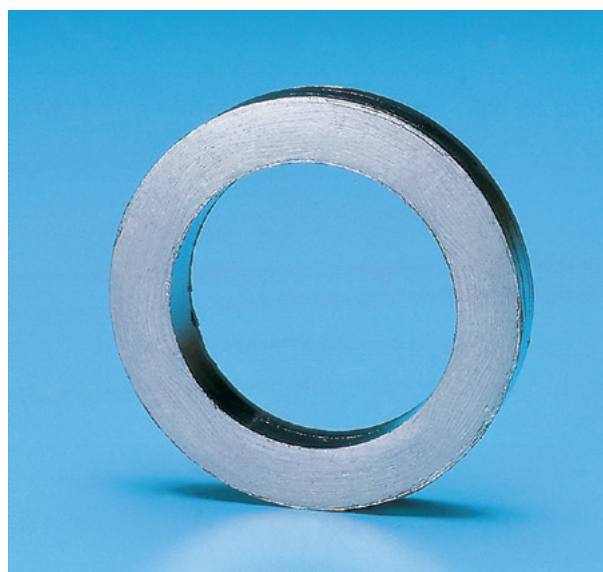

TOMBO No.2205-P

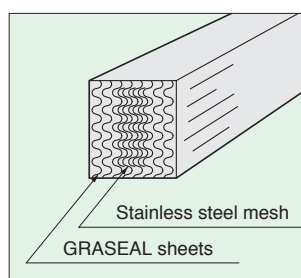

Fig. 1 TOMBO No.2205 Cross-section

- For packings with cross-sectional dimensions of less than 4 mm, stainless steel mesh is not incorporated.

Standard Dimensions

The TOMBO No.2200 series, TOMBO No.2205 series, TOMBO No.2250-A, and TOMBO No.2930 products are ring form.

The TOMBO No.2200 series, TOMBO No.2205 series, and TOMBO No.2930 products are normally manufactured with a single 45 degree bias cut, and the TOMBO No.2250-A is normally manufactured with a single straight cut.

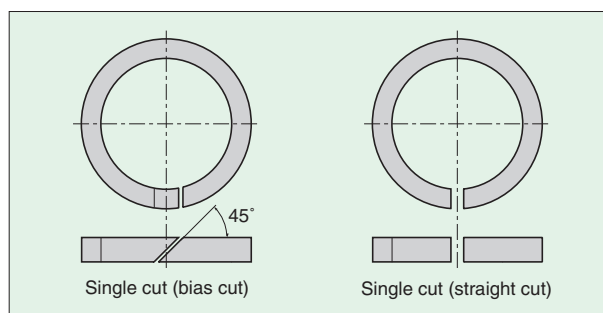

Fig. 2 Cutting Method

Ordering Information

Please specify the ring ID, OD, height, and number of packings. Please order TOMBO No.2250-A and TOMBO No.2930 (etc.) adapter packings along with TOMBO No.2200 series and TOMBO No.2205 series packings.

High Temperature Use Adapter Packings

Low Torque Adapter Packing

TOMBO™ No.2250-A

Construction

TOMBO No.2250-A features a core of Carbonized fiber. The exterior of the core is made of expanded graphite (GRASEAL), strengthened with heat resistant metal (316L stainless steel) filaments and treated with a special lubricant, graphite, and anti-corrosion materials. This adapter packing is well suited to high temperature and high pressure valves.

Features

1. When used with a GRASEAL packing, provides the same seal performance as our conventional GRASEAL packing sets (TOMBO No.2205-L with TOMBO No.2930, etc.) while greatly lowering friction resistance.
2. Little differences in performance from cryogenic to high temperatures.
3. Expanded graphite (GRASEAL) has chemical resistance properties second only to PTFE, and can be used with almost any fluid (**with the exception of those listed on page 6**).
4. Less weight loss at high temperatures than asbestos packings, with little stress relaxation.

Service Range

Temperature range	— 240 ~ 400°C (oxidizing atmosphere, in air) — 240 ~ 600°C (non-oxidizing atmosphere)
Max. Pressure	78MPa (when used with a TOMBO No.2205-P or other GRASEAL packing)
Pressure Class	4500



TOMBO No.2250-A

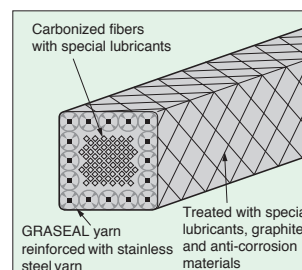

Fig. 3 TOMBO No.2250-A Cross-section

- For nominal dimensions of 5.0 mm or less, a coreless square braid construction is used.

High Temperature Use Adapter Packings

HIGH GUARD™ Packing

TOMBO™ No.2930

Construction

TOMBO No.2930 features an expanded graphite (GRASEAL) core covered with braided stainless steel, and treated with lubricants, graphite, and anti-corrosion materials. This adapter packing is well suited to high temperature and high pressure valves.

Features

1. Superior sealing performance compared to asbestos products when used with a GRASEAL packing.
2. Little differences in performance from cryogenic to high temperatures.
3. Expanded graphite (GRASEAL) has chemical resistance properties second only to PTFE, and can be used with almost any fluid (**with the exception of those listed on page 6**).
4. Less weight loss at high temperatures than asbestos packings, with little stress relaxation.

Service Range

Temperature range	— 240 ~ 400°C (oxidizing atmosphere, in air) — 240 ~ 600°C (non-oxidizing atmosphere)
Max. Pressure	78MPa (when used with a TOMBO No.2205-P or other GRASEAL packing)
Pressure Class	4500

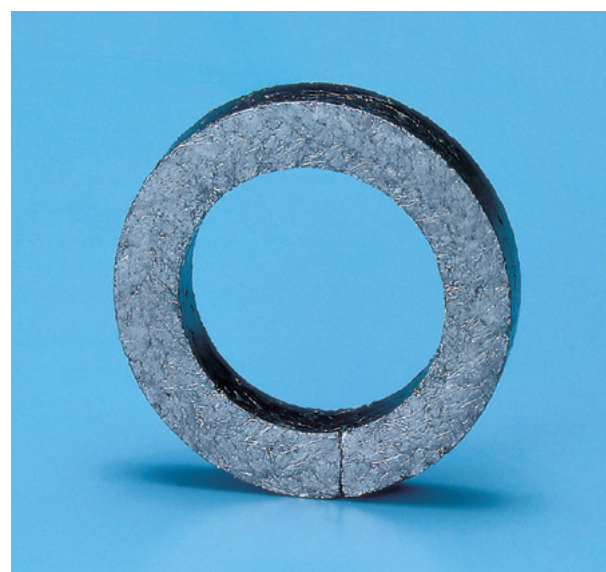

TOMBO No.2930

High Temperature Use Packings

Super Seal Packing

TOMBO™ No.2280-S

Construction

This is high temperature valve packing made of GRASEAL (expanded graphite) reinforced with stainless steel 316L filaments.

Finished with special lubricant, graphite and anti-corrosion materials.

Features

1. As this is stored in coil form, this can be used for emergency requirements.
2. Superior sealing performance can be expected in comparison with asbestos braided packings.
3. Expanded graphite (GRASEAL) has excellent chemical resistance next only to PTFE and can be used against almost all fluids except the prohibited fluids listed in the table on the right.
4. Applicable alone without use of adapter packings.
5. To facilitate inserting the packing into stuffing box, packings in coil form have rectangular cross-section.
6. As this is treated with our original anticorrosive, this has an excellent anticorrosive performance and is applicable to 13-chrome steel valve shaft.

Application

Thermal power plants, petroleum refineries, shipbuilding, chemical plants, cryogenic services, high temperature gas plants, etc.

Cast steel valves, forged steel valves, stainless steel valves, etc.

Service Range

Temperature range	– 240 ~ 400°C (oxidizing atmosphere, in air) – 240 ~ 600°C (non-oxidizing atmosphere)
Max. Pressure	25MPa
Pressure Class	1500

Note: Our experience to date shows that these packings may be used up to pressure classes of 1500, but the recommended class is 900 or below.

Please contact us concerning packings for gas seals that will be used at pressures exceeding 10 MPa or steam seals that will be used at pressures exceeding 19 MPa.

Standard size and weight

TOMBO No.	Nominal size (mm)	3.0 (3.2)	5.0 (4.8)	6.5 (6.4)	8.0 (7.9)	9.5 (9.5)	11.0 (11.1)	12.5 (12.7)	14.5 (14.3)	16.0 (15.9)	19.0 (19.0)	22.0 (22.2)	25.5 (25.4)	Supply form
2280-S	Width (mm)	2.5	4.0	5.5	7.0	8.0	9.5	11.0	12.5	14.0	16.5	19.0	22.5	3meter /coil
	Height (mm)	4.5	8.5	11.0	13.0	14.5	15.7	16.5	19.5	20.0	24.0	26.0	30.0	
	Weight (kg) ⁽¹⁾	0.054	0.130	0.222	0.335	0.420	0.490	0.550	0.770	0.890	1.270	1.550	2.150	
	Braiding	Square braid						Braid over braid						

Notes: (1)Reference weight for 1 coil



TOMBO No.2280-S

Fluids

Water type fluids (water, hot water, steam, etc.), Oil type fluids (oil, heat transfer oil, etc.), organic solvents, hydrocarbons, gaseous fluids (hydrogen, ammonia, etc.), chemical products, corrosive fluids (other than oxidizing fluids), and cryogenic fluids (LN₂, liquid air, LNG, LPG, etc.).

⚠ Not applicable

Type	Fluid name
Oxidizing acids	Nitric acid, concentrated sulphuric acid, hot sulphuric acid, mixed acids, chromic acid, etc.
Oxidizing salts	Nitrate, chlorate, hypochlorite, etc.
Halogen compounds	Bromine, fluorine, iodine, chlorine dioxide, etc.
Combustion promoting gas	Oxygen (pure oxygen)

Ordering Information

Molded Ring - Please specify ring ID, OD, height and number of rings.

Coil Form - Please specify nominal size and quantity.

High Temperature Use Packings

GRASEAL™ Packing RP (Ribbon Pack)

TOMBO™ No.2220

Construction

Crinkled GRASEAL tape without adhesion, designed for use as packing. Just with wrapping tape to stem or shaft, then stuffing, endless packing can be formed.

Easily installed for small diameter valves. This packing is also used for emergencies when spare packings are not available. For small diameter, narrow tape type, TOMBO No.2225, GRASEAL Packing-SP is also available.

Fluids

Water type fluids (water, hot water, steam, etc.), Oil type fluids (oil, heat transfer oil, etc.), organic solvents, hydrocarbons, gaseous fluids (hydrogen, ammonia, etc.), chemical products, corrosive fluids (other than oxidizing fluids), and cryogenic fluids (LN₂, liquid air, LNG, LPG, etc.).

Service Range

Temperature range	— 240~400°C (oxidizing atmosphere, in air) — 240~1650°C (non-oxidizing atmosphere)
Max. Pressure	43MPa



TOMBO No.2220-RP

Standard Size & Package

Thickness (mm)	Width (mm)	Lenght (m)	Package
0.45	6.4	7.2	Plastic Case
	12.7	7.2	
	19.0	14.2	
	25.4	14.2	

Selection Guidelines for High Temperature Use Packings

Number of Rings and Tightening Stress

Table 1 shows the recommended number of rings (combination method), tightening stress, and compression ratios for high temperature use packings (low torque combination GRASEAL packings and Super Seal packings)

Because these packings have exceptional sealing performance, sufficient seal performance may be achieved with a fewer number of rings as compared to when using asbestos packings.

Table 1 Number of Rings and Tightening Stress for High Temperature Use Packings

TOMBO No.	2205P+2250-A			2280-S		
Class	Number of Rings	Tightening Stress N/mm ²	Compression Ratio %	Number of Rings	Tightening Stress N/mm ²	Compression Ratio %
150	1+2+1	20~30	16	5	15~25	14
300	1+2+1	20~30	16	5	15~25	14
400	1+3+1	25~35	17	6	20~30	14
600	1+3+1	25~35	17	6	20~30	14
900	1+4+1	30~40	17	7	25~35	14
1500	1+4+1	35~45	18	7	25~35	14
2500	1+4+1 1+5+1	40~50	19	—	—	—

* The number of rings for the 2205P + 2250-A combination is shown as the number counted from the atmospheric side. Compression ratios are guidelines for when the recommended tightening stress are used.

Alignment of Packing Combinations

As a rule, our TOMBO No.2200 series, TOMBO No.2205 series, TOMBO No.2250-A and TOMBO No.2930 products cannot be used alone. The TOMBO No.2200 or TOMBO No.2205 packing should be sandwiched between the TOMBO No.2250-A or TOMBO No.2930 (etc.) adapter packings, as shown in the diagram below.

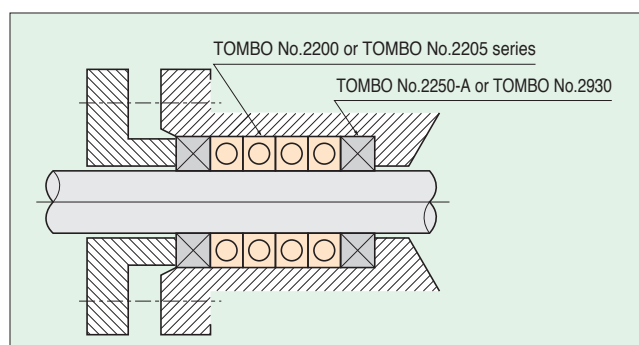

Fig. 4 A High Temperature Use Valve Packing Combination

Metal Sleeve Usage

Because these packings have exceptional sealing performance, sufficient seal performance may be achieved with a fewer number of rings as compared to when using asbestos packings. For existing valves that use a large number of packing rings, we recommend the use of a metal sleeve in order to avoid excess friction resistance.

Metal sleeve specifications are as follows:

- **Material:** SUS304 or SUS403, etc.
- **Shape:** double split
- **Dimensions**
 - Inner Diameter:** Stem diameter + 0.5 mm (deviation tolerance h7)
 - Outer Diameter:** Stuffing box diameter - 0.2 mm (deviation tolerance H7)
 - Height:** $Ls = D - n \times hp$
 - Ls :** Sleeve Height (mm)
 - D :** Box Depth (mm)
 - n :** Number of Packing Rings
 - hp :** Nominal Packing Height of 1 Ring (mm)

Sleeve Load

Sleeve resistance of packings is indicated by μk value. The μk value is determined experimentally according to the following formula, and the resulting μk values are shown in Table 2 below.

(1) Stem travel resistance

$$F = \mu \cdot k \cdot \pi \cdot D \cdot H \cdot P$$

(2) Stem torque

$$T = \frac{F \cdot D}{2} \times \frac{1}{1000}$$

The variables are:

F : Stem travel resistance (N)

T : Stem torque (N/m)

μ : Frictional coefficient

k : Lateral pressure coefficient

D : Stem diameter (mm)

H : Packing height (mm)

P : Packing tightening pressure (N/mm²)

Caution: When installing a TOMBO No.2200 series or TOMBO No.2205 series single cut product, be sure to open the packing in the axial direction, as shown in A of Fig. 5. Opening the packing as shown in B could result in damage.

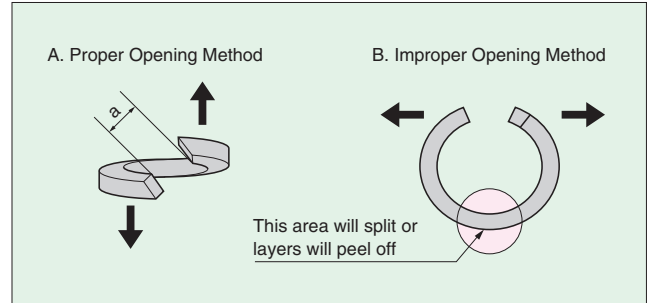

Fig. 5 Proper Installation

Table 2 μk Values of High Temperature Packings

Packing Type	μk Value
TOMBO No.2205-P+TOMBO No.2250-A Low torque combination GRASEAL packing	0.03~0.04
TOMBO No.2205-L+TOMBO No.2930 Combination GRASEAL packing	0.05~0.07
TOMBO No.2280-S Super Seal packing	0.03~0.04

Note: μk values (frictional coefficient \times lateral pressure coefficient) have been experimentally determined, but these values can vary depending on a large number of factors such as the size of the packing, the number of rings, magnitude of the tightening force, stem diameter, stem finishing precision, temperature, internal pressure, etc., meaning that an absolute μk value does not exist. When designing actuators, etc., please take into account a sufficient safety factor.

General Purpose Packings

THERMALFLON™ Packing

TOMBO™ No.9044

Construction

This is a general use packing, composed of inorganic fibers, that has treated with PTFE dispersion and includes small amounts of a special lubricant.

Features

1. As this is in white color, this is applicable for production lines where packings in black color are not acceptable. This enables improvement in working environment.
2. Most economical among packings for use in valve.

Application

Oil refineries, shipbuilding, chemical plants etc.
General use valves, ductile valves, malleable cast valves, cast steel valves, etc.

Fluid

Water type fluids (water, steam etc.), oil type fluids (with the exception of aromatic oil and heat transfer oil).

Service Range

Max. Temperature	180°C
Max. Pressure	3MPa
Pressure Class	150

Standard size and weight

TOMBO No.	Nominal size (mm)	3.2	4.8	6.4	7.9	9.5	11.1	12.7	14.3	15.9	19.0	22.2	25.4	Supply form
9044	Weight (kgs) ⁽¹⁾	0.05	0.11	0.20	0.30	0.42	0.57	0.72	0.93	1.14	1.62	2.19	2.85	3 meter /coil
	Braiding method	Square braid					Braid over braid							

Notes: (1) Molded ring is also available. * Weight is per coil and reference only.



TOMBO No.9044

Ordering Information

Molded Ring - Please specify ring ID, OD, height and number of rings.

Coil Form - Please specify nominal size and quantity.

- ⊘ TOMBO No.9044 can not be used for fluoric acid, alkalis, aromatic oils and thermal oils.
- ⚠ For semi-conductor use where contamination is not allowed, please use TOMBO No.9027-H.

Packings for valves

NAFLON™ Carbon Fiber Packing

TOMBO™ No.9077

Construction

This is a chemical use packing composed of carbon fiber yarn that treated with PTFE dispersion. The standard product is coil form but molded ring is also available.

Features

1. Excellent heat resistance
2. Excellent chemical resistance and it can be used with most chemicals except oxidizing acids.
3. Excellent conformity to shaft allow for good seal performance at low tightening stress.

Application

Thermal power plants, oil refineries, shipbuilding, chemical plants, low temperature plants, etc.
General use valves, ductile valves, malleable cast valves, etc.

Service Range

Temperature range	- 200 ~ 300°C
Max. Pressure	5MPa
Pressure Class	300

⊘ TOMBO No.9077 can not be used for oxidizing acids (Nitric acid, Hydrochloric acid, Chromic acid, Aqua regia etc.).

⚠ For semi-conductor use where contamination is not allowed, please use TOMBO No.9027-H.

Standard size and weight

TOMBO No.	Nominal size (mm)	3.2	4.8	6.4	7.9	9.5	11.1	12.7	14.3	15.9	19.0	22.2	25.4	Supply form
9077	Weight (kgs) ⁽¹⁾	—	0.08	0.14	0.21	0.30	0.45	0.54	0.69	0.84	1.20	1.62	2.12	3 meter /coil
	Braiding method	Square braid						Interlocking braid						

Notes: (1) Molded ring is also available. * Weight is per coil and reference only.



TOMBO No.9077

Fluid

Water type fluids (water, steam etc.), oil type fluids (oil, heat transfer oil, etc.), organic solvents, hydrocarbons, chemical products, corrosive fluids (other than oxidizing acids) and low temperature fluids.

Ordering Information

Molded Ring - Please specify ring ID, OD, height and number of rings.

Coil Form - Please specify nominal size and quantity.

Anti-corrosion use packings

NAFLON™ Fiber Packing-T

TOMBO™ No.9033 / 9034

Construction

This is a chemical use packing made from 100% PTFE fibers. TOMBO No.9033 is a packing made only from PTFE fibers. TOMBO No.9034 is TOMBO No.9033 treated with PTFE dispersion.

Features

1. Excellent chemical resistance and it can be used with most chemicals from strong acids to strong alkalis.
2. For TOMBO No.9033, no dissolution or elution even when used with solvents or fine chemicals.

* Conforms to the Standards and criteria for food and food additives, etc. (3-D-2, Public Notice No. 370 of the Ministry of Health & Welfare, 1959) stipulated by the Food Sanitation Act

3. As PTFE is self lubricating, valve stem torque is lower than that of asbestos packing.

Application

Chemical plants, semi-conductor related facilities, etc.

Service Range

TOMBO No.	9033	9034
Max. Temperature	260°C	260°C
Max. Pressure ⁽¹⁾	—	5MPa
Pressure Class ⁽¹⁾	—	300

Notes: (1) These values are for TOMBO No.9034 only.

Standard size and weight

TOMBO No.	Nominal size (mm)	3.2	4.8	6.4	7.9	9.5	11.1	12.7	14.3	15.9	19.0	22.2	25.4	Supply form
9033	Weight (kgs) ⁽²⁾	0.05	0.11	0.19	0.29	0.41	0.57	0.78	0.93	1.13	1.62	2.16	2.80	3 meter /coil
9034	Weight (kgs) ⁽²⁾	0.06	0.13	0.22	0.33	0.47	0.63	0.83	1.05	1.29	1.87	2.48	3.25	
	Braiding method	Square braid						Interlocking braid						

Notes: (2) Molded ring is also available. * Weight is per coil and reference only.



TOMBO No.9033

Fluid

DI water, corrosive fluids (strong acids, strong alkalis), chemicals.

⊘ This packing may not be used for alkali metal, quite strong oxidizing agent etc.

⚠ For semi-conductor use where contamination is not allowed, please use TOMBO No.9027-H.

Anti-corrosion use packings

NAFLON™ Fiber Packing-G

TOMBO™ No.9041 / 9042

Construction

This is a chemical use packing made from 100% PTFE fiber made by different way as the fiber for TOMBO No.9033, 9034.

TOMBO No.9041 is a packing made only from PTFE fibers. TOMBO No.9042 is treated with PTFE dispersion.

Service Range

TOMBO No.	9041	9042
Max. Temperature	260°C	260°C
Max. Pressure ⁽¹⁾	—	5MPa
Pressure Class ⁽¹⁾	—	300

Notes: (1) These values are for TOMBO No.9042 only.

⊘ This packing may not be used for alkali metal, quite strong oxidizing agent etc.

⚠ For semi-conductor use where contamination is not allowed, please use TOMBO No.9027-H.

Standard size and weight

TOMBO No.	Nominal size (mm)	3.2	4.8	6.4	7.9	9.5	11.1	12.7	14.3	15.9	19.0	22.2	25.4	Supply form
9041	Weight (kgs) ⁽²⁾	0.05	0.10	0.17	0.26	0.37	0.50	0.66	0.84	1.02	1.46	1.97	2.57	3 meter /coil
9042	Weight (kgs) ⁽²⁾	0.05	0.11	0.20	0.30	0.43	0.58	0.75	0.96	1.17	1.68	2.26	2.96	
	Braiding method	Square braid						Interlocking braid						

Notes: (2) Molded ring is also available. * Weight is per coil and reference only.



TOMBO No.9042

For use in oxygen line

NAFLON™ Fiber Packing-G

TOMBO™ No.9042-OX

Construction

Stretched and reinforced PTFE fiber is braided into square cross section and impregnated with PTFE dispersion and is processed in special cleansing.

Features

1. As this is easy to cut and hard to ravel from cut edge, it is easy to handle.
2. As this is 100% PTFE and does not contain lubricant, this is applicable in oxygen lines.

Application

Valves for use in oxygen lines.



TOMBO No.9042-OX

Service Range

Max. Temperature	260°C
Max. Pressure	5.2MPa
Pressure Class	300

⊘ In some cases this can not be used for alkali metals and extremely strong oxidizing agent.

⚠ TOMBO No.9027-H is recommendable for use in semi-conductor industries where contamination should be avoided.

⚠ Metal-molded packing in ring form is also available, but it would be contaminated with rust preventive oil or metallic coloring deriving from the metal mold.

Standard size and weight

TOMBO No.	Nominal size (mm)	3.2	4.8	6.4	7.9	9.5	11.1	12.7	14.3	15.9	19.0	22.2	25.4	Supply form
9042-OX	Weight (kgs) ⁽¹⁾	0.06	0.12	0.20	0.31	0.44	0.59	0.78	0.99	1.20	1.72	2.32	3.02	3 meter /coil
	Braiding method	Square braid						Interlocking braid						

Notes: (1) Molded ring is also available. * Weight is per coil and reference only.

Other Packings for valves

Graphite Fiber Packing

TOMBO™ No.2940

A high temperature packing manufactured from graphite fiber and treated with a special lubricant.

Excellent in heat and chemical resistance.

Service Range

Max. Temperature	400°C (in oxidizing atmosphere)
	600°C (in non-oxidizing atmosphere)
Max. Pressure	2MPa

* Above values show maximum for each condition.

It can not be used at maximum temperature with maximum pressure.

Standard size and weight

Nominal size (mm)	3.2	4.8	6.4	7.9	9.5	11.1	12.7	14.3	15.9	19.0	22.2	25.4	Supply form
Weight (kgs) ⁽¹⁾	0.04	0.09	0.15	0.21	0.33	0.42	0.54	0.69	0.84	1.20	1.62	2.10	3 meter /coil
Braiding method	Square braid					Braid over braid							

Notes: (1) Molded ring is also available.

* Weight is per coil and reference only.



TOMBO No.2940

Other Packings for valves

AL-METAL™ Packing -AF

TOMBO™ No.2788-AF

Made from crinkled aluminium foil treated with a special lubricant and graphite. Flexible and resilient among metallic packings and excellent heat dispersal properties.

To be used in combination with TOMBO No.2200 or TOMBO No.2205-P.

Service Range

Max. Temperature	550°C
------------------	-------

Standard size and weight

To be supplied in ring form. Please specify ring ID, OD, Height and number of rings.



TOMBO No.2788-AF

Other Packings for valves

Plastic Graphite Packing -NA

TOMBO™ No.2996-NA

This plastic packing is a mixture of special heat resistant fibers, graphite, and synthetic rubber, mold formed into a ring shape. Superior flexibility aids in valve stem conformation, making for an excellent seal. A good packing for water, hot water, low pressure steam, oils, bronze gas valves, and cast steel valves.

Service Range

Max. Temperature	200°C
Max. Pressure	2MPa

* Above values show maximum for each condition.

It can not be used at maximum temperature with maximum pressure.

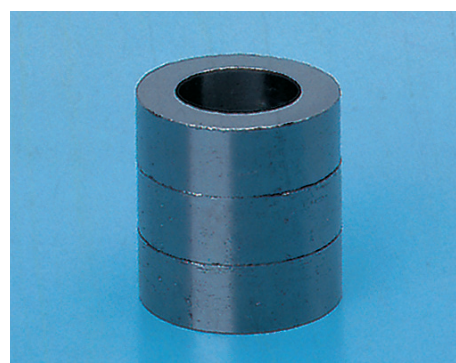

TOMBO No.2996-NA

Packing Recommendations - Rotary Shaft Packings

Fluid	Operating Conditions				Recommended Packing	Remarks
	Temperature (°C)	Pressure MPa	Shaft Speed m/s	PV Value MPa·m/s {kgf/cm ² ·m/s}		
Hot Water Water	260	2	16	15	9038	
			10	16.5	9077-L	
	200	2	16	16.5	9039	
			10	5.0	9079	
Light oil, Naphtha, Heavy oil, Crude oil, Lubricant	260	2	16	15	9038	
			10	16.5	9077-L	
	200	2	16	16.5	9039	
Alcohol, Ester, Amine, Ketone, Aromatic hydrocarbons	260	2	16	15	9038	
			10	16.5	9077-L	
	200	2	16	16.5	9039	
Weak Alkali 7<pH<12	260	2	16	15	9038	
			10	16.5	9077-L	
			8	10	9036	
	200	2	16	16.5	9039	
Strong Alkali 12≤pH≤14	260	2	16	15	9038	
			10	16.5	9077-L	
			8	10	9036	
Weak acids 2<pH<7	260	2	16	15	9038	
			10	16.5	9077-L	
			8	10	9036	
	200	2	16	16.5	9039	
Strong acids 0≤pH≤2	260	2	16	15	9038	Not used for strong oxidizing acids
			10	16.5	9077-L	Not used for strong oxidizing acids
			8	10	9036	
Strong oxidizing acids	260	2	8	10	9036	Nitric acids, Hot sulphuric acids Chromic acids etc.

* This selection guide shows typical recommended packings for fluids, temperatures, pressures, shaft speeds and PV values and not showing maximum condition of each rotary shaft packings. Thus, depending on the other conditions, the products shown here are not necessarily suitable for use in some cases.

* For maximum service condition of each rotary shaft packings, please refer to the description of each product in this catalogue.

* Rotary shaft packings are basically operated with small amount of leakage to keep lubricity etc. In case leakage of the internal fluid is not allowed, lantern ring shall be used and the fluid which leakage is allowed shall be filled at 0.1~0.2MPa (1~2kgf/cm²) higher pressure than internal pressure.

Packings for use in rotating equipment

Packings for use in rotating equipment are sealing materials to prevent leakage from the contact area of the shaft of rotating equipment such as pumps, stirring machines and so on.

Versatile packing

NAFLON™ impregnated CT Packing

TOMBO™ No.9079

Construction

Flexible cotton yarn is braided into square cross section and treated with PTFE dispersion and special lubricant.

Features

1. As this is in white color, this is applicable for production lines where packings in black color are not acceptable. This enables improvement in working environment.
2. Most economical among packings for use in rotating equipment.
3. As this is excellent in flexibility, it can be expected that this fits into the shaft and the wearing is reduced.

Application

A wide variety of pumps, stirring machines, etc.

Fluid

Water-based fluids (Clear water, industrial and sanitary sewage, seawater, etc.).

⊘ This would catch fire when this is used in temperatures above the maximum temperature.



TOMBO No.9079

Service Range

Max. Temperature	100°C
Max. Pressure	1.0MPa
Max. Velocity	10meter/sec
Max. PV Value	5MPa · m/sec
pH	4 ~ 10

Anti-corrosion use packing

NAFLON™ Fiber Packing-G

TOMBO™ No.9042-S / 9042-OX

Construction

TOMBO No.9042-OX is made of stretched and reinforced PTFE fiber that is braided into square cross section and impregnated with PTFE dispersion and is processed in special cleansing.

TOMBO No.9042-S is made by treating TOMBO No.9042-OX with silicon-based lubricant.

Features

1. As this is easy to cut and hard to ravel from cut edge, it is easy to handle.
2. As this is made of PTFE, this is outstandingly low in sliding.

Application

Shaft seal of rotating equipment, Screw feeders, Stirring shafts, Pumps.

⊘ TOMBO No.9042-OX does not contain lubricant, in order to use stably for rotating equipment please use other packings or please use TOMBO No.9042-OX together with TOMBO No.9401 Fluorine Grease.

⚠ Metal-molded packing in ring form is also available, but it could be contaminated with rust preventive oil and metallic coloring that derive from the metal mold.



TOMBO No.9042-OX

Service Range

Max. Temperature	260°C
Max. Pressure	2MPa
Max. Velocity	4meter/sec
Max. PV Value	4MPa · m/sec
pH	0 ~ 14

Anti-corrosion use packing

G-FLON™ Packing

TOMBO™ No.9038

Construction

Graphite particles containing PTFE yarn is treated with PTFE dispersion and special lubricant, and then braided into square cross section and further treated with PTFE dispersion.

Features

1. Graphite particles containing PTFE yarn is excellent in chemical resistance and can be used with almost any fluids other than strong oxidizing acids.
2. Excellent in seal performance at high revolution speeds.
3. Because it contains graphite particles in PTFE yarn, heat dispersion characteristics are very good and among PTFE base packings, it has the highest heat resistance.

Application

All types of pumps, mixers, etc.

Fluid

Water base fluids (water, waste water, brine etc.), oil base fluids, organic solvents, hydrocarbons, chemicals, corrosive fluids except listed below.

- ⊗ TOMBO No.9038 can not be used for strong oxidizing acids such as fuming sulfuric acid, concentrated sulfuric acid, chromic acid, aqua regia etc.
- ⊗ This packing is not used for the fluids which contamination is not allowed, such as drinking water, pharmaceuticals, comestibles, semi-conductor manufacturing etc.



TOMBO No.9038

Service Range

Max. Temperature	260°C
Max. Pressure	2MPa
Max. Velocity	16meter/sec
Max. PV Value	15MPa · m/sec
pH	0 ~ 14

Standard size and weight

TOMBO No.	Nominal size (mm)	3.2	4.8	6.4	7.9	9.5	11.1	12.7	14.3	15.9	19.0	22.2	25.4	Supply form
9079	Weight (kgs) ⁽¹⁾	—	0.08	0.15	0.22	0.32	0.43	0.57	0.71	0.88	1.24	1.67	2.16	3 meter /coil
	Braiding method	Square braid					Interlocking braid							
9042-S	Weight (kgs) ⁽¹⁾	0.06	0.13	0.21	0.33	0.46	0.63	0.83	1.05	1.28	1.83	2.47	3.22	
	Braiding method	Square braid					Interlocking braid							
9042-OX	Weight (kgs) ⁽¹⁾	0.06	0.12	0.20	0.31	0.44	0.59	0.78	0.99	1.20	1.72	2.32	3.02	
	Braiding method	Square braid					Interlocking braid							
9038	Weight (kgs) ⁽¹⁾	0.06	0.11	0.18	0.28	0.41	0.55	0.72	0.92	1.12	1.59	2.17	2.84	
	Braiding method	Square braid					Interlocking braid							

Notes: (1) Molded ring is also available. * Weight is per coil and reference only.

Anti-corrosion use packing

NAFLON™ Fiber Packing (Soft)

TOMBO™ No.9036

Construction

This packing is made of PTFE fiber and finished with PTFE dispersion and heat resistant lubricant.

Features

1. PTFE is extremely chemical resistant, and can be used with almost any fluids from strong acids to strong alkalis.
2. Contamination of the fluid from this packing is very little.

Application

All types of pumps, mixers, etc.

Fluid

Water base fluids (water, waste water, brine etc.), oil base fluids, organic solvents, hydrocarbons, chemicals, corrosive fluids.

- ⊘ This packing is not used for the fluids which contamination is not allowed, such as drinking water, pharmaceuticals, comestibles, semi-conductor manufacturing etc.



TOMBO No.9036

Service Range

Max. Temperature	260°C
Max. Pressure	2MPa
Max. Velocity	8meter/sec
Max. PV Value	10MPa · m/sec
pH	0 ~ 14

Standard size and weight

TOMBO No.	Nominal size (mm)	3.2	4.8	6.4	7.9	9.5	11.1	12.7	14.3	15.9	19.0	22.2	25.4
9036	Weight (kgs) ⁽¹⁾	0.07	0.14	0.23	0.35	0.49	0.67	0.86	1.09	1.34	1.92	2.57	3.37
	Braiding method	Square braid						Interlocking braid					
	Supply form	3 meter / coil											

Notes: (1) Molded ring is also available. * Weight is per coil and reference only.

Anti-corrosion use packing

NAFLON™ Fiber Packing - T

TOMBO™ No.9033 / 9034

Construction

These packings are for chemical packings made of PTFE fiber. TOMBO No.9033 does not contain any lubricant. TOMBO No.9034 is treated with PTFE dispersion.

Features

1. PTFE is extremely chemical resistant, and can be used with almost any fluids from strong acids to strong alkalis.
2. This is ideal packing for chemical services because it will leave almost no elution even in solvents or fine chemicals.

Application

All types of pump, mixers, etc.

- ⚠ PTFE fiber is not suitable for high speed rotation due to its high coefficient of thermal expansion and low thermal conductivity.

Fluid

Water base fluids (water, waste water, brine etc.), oil base fluids, organic solvents, hydrocarbons, chemicals, corrosive fluids (strong acids, strong alkalis).

- ⚠ As TOMBO No.9033 does not contain lubricant etc. please use other packings or please use TOMBO No.9042-OX together with either TOMBO No.9401 Fluorine Grease or lubricant that does not affect the fluid such as edible oil, etc.



TOMBO No.9034

Service Range

Max. Temperature	260°C
Max. Pressure	2MPa
Max. Velocity	4meter/sec
Max. PV Value	4MPa · m/sec
pH	0 ~ 14

Standard size and weight

TOMBO No.	Nominal size (mm)	3.2	4.8	6.4	7.9	9.5	11.1	12.7	14.3	15.9	19.0	22.2	25.4
9033	Weight (kgs) ⁽¹⁾	0.05	0.11	0.19	0.29	0.41	0.57	0.78	0.93	1.13	1.62	2.16	2.80
	Braiding method	Square braid					Interlocking braid						
9034	Weight (kgs) ⁽¹⁾	0.06	0.13	0.22	0.33	0.47	0.63	0.83	1.05	1.29	1.87	2.48	3.25
	Braiding method	Square braid					Interlocking braid						
	Supply form	3 meter / coil											

Notes: (1) Molded ring is also available. * Weight is per coil and reference only.

Anti-corrosion use packing

NAFLON™ Carbon Fiber Packing - L

TOMBO™ No.9077-L

Construction

Carbon fiber is braided into square cross section and impregnated with PTFE dispersion and special lubricant.

Features

1. Good in heat resistance.
2. Carbon fiber is extremely chemical resistant, and can be used with almost any fluid other than strong oxidizing acids.
3. Maintain excellent seal performance for long time.
4. Less sleeve torque than asbestos packing.

Application

All types of pumps, mixers, etc.

Fluid

Water base fluids (water, waste water, brine etc.), oil base fluids, organic solvents, hydrocarbons, black / green / white liquor for paper mill, chemicals, corrosive fluids except listed below.

- ⊘ TOMBO No.9077-L can not be used for strong oxidizing acids such as fuming sulfuric acid, concentrated sulfuric acid, chromic acid, aqua regia etc.
- ⊘ This packing is not used for the fluids which contamination is not allowed, such as drinking water, pharmaceuticals, comestibles, semi-conductor manufacturing etc.



TOMBO No.9077-L

Service Range

Max. Temperature	260°C
Max. Pressure	2MPa
Max. Velocity	10meter/sec
Max. PV Value	16.5MPa · m/sec
pH	0 ~ 14

Standard size and weight

TOMBO No.	Nominal size (mm)	3.2	4.8	6.4	7.9	9.5	11.1	12.7	14.3	15.9	19.0	22.2	25.4
	Weight (kgs) ⁽¹⁾	—	0.11	0.20	0.30	0.40	0.54	0.70	0.89	1.09	1.57	2.20	2.75
9077-L	Braiding method	Square braid					Interlocking braid						
	Supply form	3 meter / coil											

Notes: (1) Molded ring is also available. * Weight is per coil and reference only.

General Purpose Packing

Aramid Fiber Packing

TOMBO™ No.9040

Construction

This packing is made of polyamide fiber and finished with PTFE dispersion and heat resistant lubricant.

Features

1. Better wear resistance than other packings and it allows long and stable seal performance. More suitable for slurries than other packings.
2. Good in heat resistance.

Application

All types of pumps, mixers, plungers etc.
Suitable for the application at pulp or paper mills.

Fluid

Water base fluids (water, waste water, brine etc.), oil base fluids, organic solvents, hydrocarbons, weak acids, weak alkalis.

- ⊘ This packing is not used for the fluids which contamination is not allowed, such as drinking water, pharmaceuticals, comestibles, semi-conductor manufacturing etc.



TOMBO No.9040

Service Range

Max. Temperature	260°C
Max. Pressure	2MPa
Max. Velocity	10meter/sec
Max. PV Value	16.5MPa · m/sec
pH	2 ~ 13

Standard size and weight

TOMBO No.	Nominal size (mm)	3.2	4.8	6.4	7.9	9.5	11.1	12.7	14.3	15.9	19.0	22.2	25.4	
9040	Weight (kgs) ⁽¹⁾	—	0.12	0.20	0.29	0.42	0.57	0.74	0.95	1.14	1.65	2.19	2.85	
	Braiding method	Square braid					Interlocking braid							
	Supply form	3 meter / coil												

Notes: (1) Molded ring is also available. * Weight is per coil and reference only.

General Purpose Packing

Aramid Fiber Packing - White

TOMBO™ No.9040-W / 9040-WR

Construction

These packings are made of aramid fiber.
 TOMBO No.9040-W is finished with PTFE dispersion and heat resistant lubricant.
 TOMBO No.9040-WR is finished with PTFE dispersion. Lubricant is not used.

Features

1. White color for lines that can not use black color products.
2. More flexible than TOMBO No.9040 and it allows excellent conformity to shaft and reduces shaft wearing.

Application

All types of pump, mixers, dampers, etc. General application at pulp and paper mills.
 TOMBO No.9040-WR is suitable for the lines which lubricant is not allowed.

Fluid

Water base fluids (water, waste water, brine etc.), oil base fluids, organic solvents, hydrocarbons, weak acids, weak alkalis pulp slurry, white liquor.

- ⊘ This packing is not used for the fluids which contamination is not allowed, such as drinking water, pharmaceuticals, comestibles, semi-conductor manufacturing etc.



TOMBO No.9040-W

Service Range

TOMBO No.	9040-W	9040-WR
Max. Temperature	260°C	260°C
Max. Pressure	2MPa	2MPa
Max. Velocity	10meter/sec	8meter/sec
Max. PV Value	16.5MPa · m/sec	10MPa · m/sec
pH	2 ~ 13	2 ~ 13

Standard size and weight

TOMBO No.	Nominal size (mm)	3.2	4.8	6.4	7.9	9.5	11.1	12.7	14.3	15.9	19.0	22.2	25.4	Supply form
9040-W	Weight (kgs) ⁽¹⁾	—	0.09	0.14	0.21	0.31	0.43	0.54	0.68	0.85	1.28	1.70	2.20	3 meter/coil
	Braiding method	Square braid					Interlocking braid							
9040-WR	Weight (kgs) ⁽¹⁾	—	0.09	0.15	0.24	0.35	0.47	0.61	0.74	0.97	1.35	1.81	2.34	
	Braiding method	Square braid					Interlocking braid							

Notes: (1) Molded ring is also available. * Weight is per coil and reference only.

General Purpose Packing

Oxidized PAN fiber Packing

TOMBO™ No.9039

Construction

This packing is made of Carbonized fiber and finished with PTFE dispersion and special lubricant.

Features

1. Good seal performance under high revolutions.
2. Less shaft and sleeve abrasion than asbestos packing.
3. Economical among packing.

Application

All types of pumps, mixers, sterntube, etc.

Fluid

Water base fluids (water, waste water, brine etc.), oil base fluids, organic solvents, hydrocarbons, weak acids, weak alkalis, slurries.

- ⊘ This packing is not used for the fluids which contamination is not allowed, such as drinking water, pharmaceuticals, comestibles, semi-conductor manufacturing etc.



TOMBO No.9039

Rotary Shaft Packings

Service Range

Max. Temperature	200°C
Max. Pressure	2MPa
Max. Velocity	16meter/sec
Max. PV Value	16.5MPa · m/sec
pH	2 ~ 12

Standard size and weight

TOMBO No.	Nominal size (mm)	3.2	4.8	6.4	7.9	9.5	11.1	12.7	14.3	15.9	19.0	22.2	25.4	
9039	Weight (kgs) ⁽¹⁾	0.05	0.11	0.19	0.29	0.38	0.52	0.67	0.85	1.05	1.49	2.01	2.63	
	Braiding method	Square braid					Interlocking braid							
	Supply form	3 meter / coil												

Notes: (1) Molded ring is also available. * Weight is per coil and reference only.

High temperature Packing

Graphite Fiber Packing

TOMBO™ No.2940

Construction

A high temperature packing manufactured from graphite fiber and treated with a special lubricant.

Features

1. Good in chemical resistance and can be used with almost any chemicals except strong oxidizing acids.
2. Can be used at high temperature where TOMBO No.9039 or TOMBO No.9077-L can not be used.

Application

All types of pump, mixers, dampers, etc.

Fluid

Water base fluids (water, waste water, brine etc.), oil base fluids, organic solvents, hydrocarbons, chemical products, corrosive fluids except strong oxidizing acid such as fuming sulfuric acid, concentrated sulfuric acid, chromic acid, aqua regia etc.

- ⊘ TOMBO No.2940 can not be used for strong oxidizing acids such as fuming sulfuric acid, concentrated sulfuric acid, chromic acid, aqua regia etc.
- ⊘ This packing is not used for the fluids which contamination is not allowed, such as drinking water, pharmaceuticals, comestibles, semi-conductor manufacturing etc.

Standard size and weight

TOMBO No.	Nominal size (mm)	3.2	4.8	6.4	7.9	9.5	11.1	12.7	14.3	15.9	19.0	22.2	25.4	
2940	Weight (kgs) ⁽¹⁾	0.04	0.09	0.15	0.21	0.33	0.42	0.54	0.69	0.84	1.20	1.62	2.10	
	Braiding method	Square braid					Interlocking braid							
	Supply form	3 meter / coil												

Notes: (1) Molded ring is also available. * Weight is per coil and reference only.



TOMBO No.2940

Service Range

Max. Temperature	400°C (in oxidizing atmosphere)
	600°C (in non-oxidizing atmosphere)
Max. Pressure	2MPa (20kgf/cm ²)
Max. Velocity	10meter/sec
Max. PV Value	10MPa · m/sec
pH	0 ~ 14

Other Packing for rotary shaft

AL-METAL™ Packing - AF

TOMBO™ No.2788-AF

Construction

This is metallic back-up packing made of aluminium foil that has been treated with a special lubricant and graphite.

Features

Flexible and resilient among metallic packings and good in heat dissipation. To be used in combination with other packings.

Service Range

Max. Temperature	550°C
Max. Pressure	depends on other packing
Max. Velocity	depends on other packing
Max. PV Value	depends on other packing
pH	5 ~ 9



TOMBO No.2788-AF

Standard size and weight

TOMBO No.	Nominal size (mm)	3.2	4.8	6.4	7.9	9.5	11.1	12.7	14.3	15.9	19.0	22.2	25.4
2788-AF	Width (mm)	—	4.5	6.0	7.5	9.0	10.0	12.0	—	15.0	18.0	21.0	24.0
	Height (mm)	—	5.0	7.0	9.5	11.0	13.0	14.0	—	18.0	22.0	25.0	28.0
	ID of coil (mm)	—	30	40	40	50	50	50	—	80	110	150	190
	Weight (kgs) ⁽¹⁾	—	0.09	0.12	0.21	0.29	0.38	0.53	—	0.90	1.10	1.43	1.83
	Supply form	3.63 meter / coil in spiral form											

Notes: (1) Molded ring is also available. * Weight is per coil and reference only.

Packings for plungers and valves

NAFLON™ PTFE Molded Packing

TOMBO™ No.9027

Construction

This is a self lip seal type packing machined from PTFE resin, available in VH, VL, and D type cross-sections. For high temperature and high pressure services, packings made of filled PTFE is also available.

Features

1. Can be used with almost any fluid.
2. Because this packing is made from PTFE, it has low frictional resistance with the stem and will not stick.
3. Will not contaminate the fluids.
4. By selecting suitable fillers, products for high temperature, pressure and wear resistant application are also available.

Fluid

Water base fluids (water, steam etc.), oil base fluids (oil, heat transfer oil etc.), organic solvent, hydrocarbons, gas type fluids (hydrogen, ammonia, etc.), chemical products, corrosive fluids (other than oxidizing fluids).

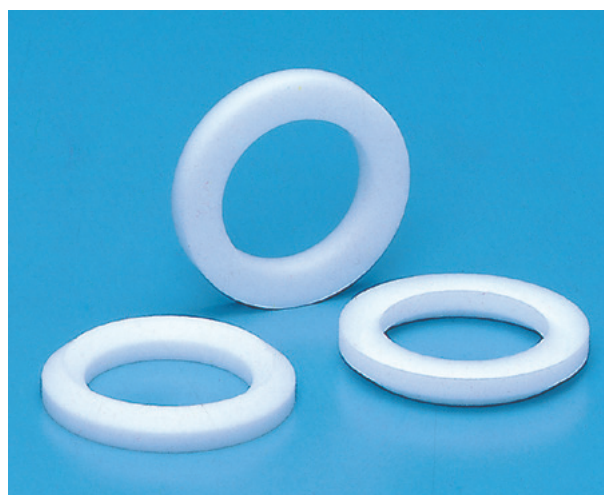

TOMBO No.9027

Service Range

Max. Temperature	200°C (Filled PTFE) 120°C (Pure PTFE)
Max. Pressure	30MPa Can be used with high pressure when combined with metal spacers.

Service Pressure, Number of Packings, Application, and Shape

Item	Type	VH-type	VL-type	D-type
Service Pressure MPa		2 ~ 30	~ 3	~ 2
Number of Packing		2 ~ 5MPa 3pcs {20 ~ 50kgf/cm ² }	3 ~ 4pcs	1 ~ 3pcs
		5 ~ 15MPa 4pcs {50 ~ 150kgf/cm ² }		
		15 ~ 30MPa 6pcs {150 ~ 300kgf/cm ² }		
Application		High pressure valves, pistons, and plungers	Low pressure valves and control valves	Low pressure valves and mechanical seals
Shape				

Typical application of NAFLON™ PTFE Molded Packing

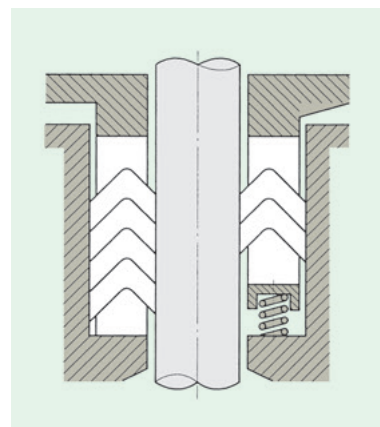

Type of Nafion PTFE Molded Packings with Fillers

TOMBO No.9027

—	H	—	G20
	Shape		Filler

Shape	Indication symbol	Filler	Indication symbol
VH-Type	H	none	—
VL-Type	L	with glass fiber	G20
D-Type	D	with glass fibers and graphite	GGR
		carbon fiber	CF10

⚠ Caution: Apply TOMBO No.9401 (Fluorine Grease) to the packing and ensure that the lip is not damaged.

⚠ Caution: For low pressure gas, apply TOMBO No.9401 (Fluorine Grease) to the packing and use with a spring (recommended spring pressure: 0.8MPa[8kgf/cm²])

⚠ Caution: Shaft surface finishing should be at least 1.6μmRa.

⚠ Caution: When used at temperatures over 120°C, use filled PTFE.

⊘ This packing may not be used for alkali metal, quite strong oxidizing agent etc.

■ Stem diameter & Width of PTFE Molded Packing unit : mm

Stem diameter (d)	Packing width
5 ~ 10	3 ~ 5
10 ~ 20	4 ~ 6.5
20 ~ 30	5 ~ 8
30 ~ 40	5 ~ 10
40 ~ 65	7 ~ 10
65 ~ 125	8 ~ 12.5
125 ~ 250	9.5 ~ 16

■ Standard dimensions of PTFE Molded Packing

● VH-type

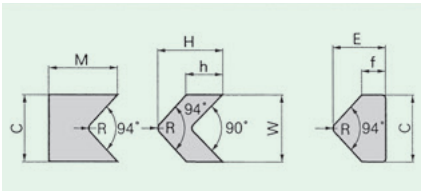

● Cross Section Dimensions of VH-type unit : mm

W	H	h	E	f	R
3	2.8	1.6	2.2	1.0	0.5
4	3.7	2.1	2.9	1.3	1.0
5	4.7	2.7	3.7	1.7	1.0
6	5.6	3.2	4.4	2.0	1.0
7	6.6	3.7	5.2	2.3	1.0
8	7.4	4.2	5.9	2.7	1.5
9	8.4	4.8	6.6	3.0	1.5
10	9.4	5.3	7.4	3.3	1.5
11	10.4	5.8	8.2	3.6	1.5
12	11.4	6.4	9.0	4.0	1.5
13	12.3	6.9	9.7	4.3	2.0
14	13.2	7.4	10.5	4.7	2.0
15	14.2	8.0	11.2	5.0	2.0
16	15.2	8.5	12.0	5.3	2.0
17	16.2	9.0	12.8	5.6	2.0
18	17.1	9.5	13.6	6.0	2.0
19	18.1	10.0	14.4	6.3	2.0
20	19.1	10.5	15.3	6.7	2.0

M=W C=W-0.2

Packing Height : M+nh+f (n=No. of packing)

● VL-type

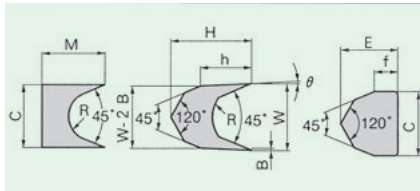

● Cross Section Dimensions of VL-type unit : mm

W	H	h	B	R	E	f	C
3	3.1	1.8	0.15	1.0	3.3	2	2.5
4	4.2	2.4	0.15	1.5	3.8	2	3.5
5	5.2	3.0	0.15	2.0	4.2	2	4.5
6	6.3	3.6	0.15	2.0	4.7	2	5.5
7	7.3	4.2	0.2	2.5	5.1	3	6.4
8	8.3	4.8	0.2	3.0	5.5	3	7.4
9	9.4	5.4	0.25	3.5	7.5	3.5	8.3
10	10.4	6.0	0.25	4.0	8.4	4	9.3
11	11.4	6.6	0.3	4.5	8.8	4	10.2
12	12.5	7.2	0.3	4.5	10.3	5	11.2
13	13.5	7.8	0.35	5.0	11.7	6	12.1
14	14.5	8.4	0.35	5.5	12.1	6	13.1
15	15.6	9.0	0.4	6.0	12.6	6	14.0
16	16.6	9.6	0.4	6.0	14.0	7	15.0
17	17.7	10.2	0.4	6.5	14.5	7	16.0
18	18.8	10.8	0.5	7.0	16.0	8	16.8
19	19.8	11.4	0.5	7.5	16.4	8	17.8
20	20.8	12.0	0.5	8.0	17.8	9	18.8

M=W

Packing Height : M+nh+f (n=No. of packing)

● D-type

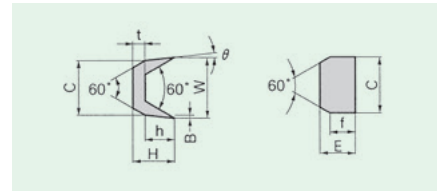

● Cross Section Dimensions of D-type unit : mm

W	H	h	t	B	E	f
3	3	2	1	0.1	3	2
3.5	3	2	1	0.1	3	2
4	3	2	1	0.1	3	2
4.5	3.5	2.5	1	0.1	3	2
5	4	3	1	0.1	3	2
5.5	4	3	1	0.1	3	2
6	4	3	1	0.1	3	2
6.5	4.25	3.25	1	0.1	3.5	2.5
7	4.5	3.5	1	0.1	4	3
8	5.5	4	1.5	0.1	4.5	3
9	6	4.5	1.5	0.15	5	3.5
10	7	5	2	0.15	6	4
11	7.5	5.5	2	0.2	6	4
12	8	6	2	0.2	7	5
13	8.5	6	2.5	0.2	7.5	5
14	9	6.5	2.5	0.2	8.5	6
15	9.5	7	2.5	0.2	8.5	6
16	10	7.5	2.5	0.2	9.5	7

W dimension less than 10mm, C=W-0.4

W dimension more than 11mm, C=W-0.6

Packing Height : nh+E (n=No. of packing)

Packings for Plungers, Rods, Rams and Pistons

Lip Type Packings

TOMBO™ No.2660 / 2661 / 2665

Construction

This type of packing is expanded automatically by fluid pressure and forms tight seal against stuffing box wall or shaft. Thus it is called automatic sealing packing.

Type

● **TOMBO No.2660 Rubber Molded Packing with Cotton duck**

Cotton duck treated with synthetic rubber is molded into ring forms.

● **TOMBO No.2661 Rubber Molded Packing**

Various kinds of rubber are molded into ring forms. It has better seal performance than TOMBO No.2660 but less pressure resistance. Service range depends on rubber material.

● **TOMBO No.2665 Slip Mold Packing**

Surface of TOMBO No.2660 is treated with PTFE dispersion for easy conformity to rod or shaft surface for initial break-in period.



TOMBO No.2660



TOMBO No.2661



TOMBO No.2665

Application

Rod and piston seals for cylinder, plungers, Hydraulic rams, valve stems.

Fluid

Water type fluids (water, waste water, sewage, brine etc.), Oil type water, Air.

Service Range of TOMBO No.2660 and 2665

	V type	U type	L type	J type	S type	AF type
Cross Section						
Max. Temperature	~ 120°C	~ 120°C	~ 120°C	~ 120°C	~ 120°C	~ 120°C
Max. Pressure	~ 200MPa	~ 100MPa	~ 10MPa	—	~ 40MPa	~ 40MPa
Max. Velocity	0.8m/sec	0.15m/sec	0.15m/sec	—	0.4m/sec	—
pH	5 ~ 9	5 ~ 9	5 ~ 9	5 ~ 9	5 ~ 9	5 ~ 9

Other Packings

Rubber O-Ring

TOMBO™ No.2670

Construction

Molded rubber O-ring.

Application

Rod seal of cylinder, piston seal, and ram.

Service Range

Max. Temperature	Depends on rubber
Max. Velocity	0.1meter / sec.
pH	Depends on rubber

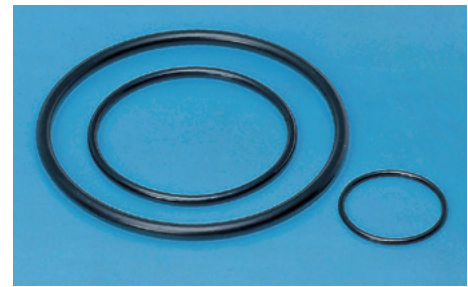

TOMBO No.2670

Fluid

Water type fluid (water, waste water, sewage, brine etc.), Various oil type fluids, Air.

Type of rubber and physical properties

Standard material		Feature	JIS symbol	Color	Working temperature range (°C)
Nichias product name	Nichias material symbol				
Nitrile elastmer	NBR	Mineral oil resistance	NBR-70-1	Black	- 30 ~ 120
Chloroprene elastmer	CR	Weaher resintance and oil resistance	—	Black	- 30 ~ 120
Ethylene Propylene elastmer	EP	Weaher resintance and water resistance	EPDM-70	Black	- 40 ~ 150
Silicone elastmer	SI	Heat resistance	VMQ-70	Reddish brown	- 50 ~ 200
Fluoro elastomer FA	FA	Heat resistance	FKM-70	Black	- 15 ~ 200
Fluoro elastomer FB	FB	Steam resistance and asid resistance	—	Black	0 ~ 200
BLAZER™ A	BA	Chemical resistance	—	Black	0 ~ 210
BLAZER™ NEXT	BNX	Heat resistance	—	Black	0 ~ 335
BLAZER™ S2	BS2	Steam resistance	—	Black	0 ~ 320

⚠ When O-ring is used more than 7MPa (70 kgf/cm²) for moving, TOMBO No.9026 PTFE Back-up ring shall be used together.

⚠ When O-ring is used for rotating equipment, enough lubrication is required.

Other Packings

NAFLON™ PTFE Back-up Ring

TOMBO™ No.9026

Construction

Machined PTFE ring. Endless ring, bias cut ring and spirally cut ring are available. Filled PTFE ring is also available.

Application



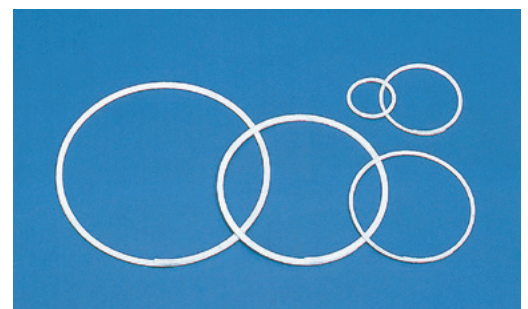





Back-up rings for rubber O-Rings for high pressue (over 7MPa).



TOMBO No.9026

Endless Type	Bias Cut Type	Spiral Type

Static sealing for industrial furnaces, ducts, manholes, doors, etc.

Appearance	TOMBO No.	Product Name	Construction
	9079	NAFLON Impregnated CT Packing	Flexible cotton yarn is braided into square cross section and treated with PTFE dispersion and special lubricant.
	9044	THERMALFLON Packing	Inorganic fiber yarn is braided into square cross section treated with PTFE dispersion and a minimal amount of special lubricant.
	2280-S	Super Seal Packing	GRASEAL (expanded graphite) reinforced with stainless steel 316L filaments is braided into rectangular cross section treated with special lubricant, graphite and anti-corrosion material.
	8510-E	Square Braided Packing-E	Fiber glass yarn is braided into square cross section.
	8520	Square Braided Packing	Alkaline earth silicate (AES) wool reinforced with wire is braided into square cross section.
	8520-G	Square Braided Packing with graphite treatment	Surface of TOMBO No.8520 is treated with graphite.
	8520-H	Square Braided Packing-H	Wire reinforced alkaline earth silicate (AES) wool is densely braided into square cross section.
	8520-BH	Square Braided Packing-BH	Alkaline earth silicate (AES) wool reinforced with wire is densely braided into square cross section with graphite-based impregnation.
	8520-WH	Square Braided Packing-WH	Alkaline earth silicate (AES) wool reinforced with wire is densely braided into square cross section with titanium-based impregnation.

* It is recommended to use it in an oxidizing atmosphere of 400°C or less and a non-oxidizing atmosphere of 600°C or less because the sealing property is deteriorated due to disappearance of the impregnating agent component.

	Features	Shape of cross section	Maximum	
			Temperature (°C)	Pressure MPa
	Most economical	Square	100	—
	Excellent in sealing performance due to dense filling treatment.	Square	180	—
	Excellent in heat resistance, chemical resistance and sealing performance.	Rectangular	400	—
	Economical	Square	400	—
	It is a packing which does not contain any impregnant.	Square	800	—
	Based on TOMBO No.8420/8520, it is a packing with improved sealability by graphite treatment.	Square	600*	—
	Compared to TOMBO No.8420/8520, it is packing with excellent sealability because it is braided at high density.	Square	800	—
	Based on TOMBO No.8420-H/8520-H, it is a packing subjected to graphite impregnation treatment in order to improve high temperature sealability.	Square	600*	—
	Based on TOMBO No.8420-H/8520-H, it is a packing subjected to titanium based impregnation treatment in order to improve high temperature sealing property.	Square	800	—

Appearance	TOMBO No.	Product Name	Construction
	8410-E	Round Braided Packing-E	Fiber glass yarn is braided into round cross section. Different from TOMBO No.8510-E only in round cross section.
	8420	Round Braided Packing	Alkaline earth silicate (AES) wool reinforced with wire is braided into round cross section. Different from TOMBO No.8520 only in round cross section.
	8420-G	Round Braided Packing with graphite treatment	Surface of TOMBO No.8420 is treated with graphite. Different from TOMBO No.8520-G only in round cross section.
	8420-H	Round Braided Packing-H	Alkaline earth silicate (AES) wool reinforced with wire is densely braided into round cross section. Different from TOMBO No.8520-H only in round cross section.
	8420-BH	Round Braided Packing-BH	Alkaline earth silicate (AES) wool reinforced with wire is densely braided into round cross section with graphite based impregnation. Different from TOMBO No.8520-BH only in round cross section.
	8420-WH	Round Braided Packing-WH	Alkaline earth silicate (AES) wool reinforced with wire is densely braided into round cross section with titanium-based impregnation. Different from TOMBO No.8520-WH only in round cross section.

* It is recommended to use it in an oxidizing atmosphere of 400°C or less and a non-oxidizing atmosphere of 600°C or less because the sealing property is deteriorated due to disappearance of the impregnating agent component.

⚠ Caution As packings include a small amount of organic substance, it would generate smoke at the beginning of temperature rise. If packings are used in high temperatures, remove organic substance by heating prior to use.

	Features	Shape of cross section	Maximum	
			Temperature (°C)	Pressure MPa
	Economical	Round	400	—
	It is a packing which does not contain any impregnant.	Round	800	—
	Based on TOMBO No.8420/8520, it is a packing with improved sealability by graphite treatment.	Round	600*	—
	Compared to TOMBO No.8420/8520, it is packing with excellent sealability because it is braided at high density.	Round	800	—
	Based on TOMBO No.8420-H/8520-H, it is a packing subjected to graphite impregnation treatment in order to improve high temperature sealability.	Round	600*	—
	Based on TOMBO No.8420-H/8520-H, it is a packing subjected to titanium based impregnation treatment in order to improve high temperature sealing property.	Round	800	—

Construction

This is lubrication grease made of fine Fluorine particles mixed with fluorinated oil as a base.

Features

Good in heat and chemical resistance, and lubrication property. It is non-combustible also.

Application

To be used as initial lubricant for braided packings, rubber molded packings and PTFE lip type packings. It is also used as grease for oxygen service.

Service Range

Max. Temperature	150°C
pH	0 ~ 14

Standard packing

50 gram / tube



TOMBO No.9401

NUMERICAL INDEX

TOMBO No.	Product Name	Page
2200	GRASEAL Packing	6
2200-L	GRASEAL Packing - L	6
2200-P	GRASEAL Packing - P	6
2205	GRASEAL Packing - M	6
2205-L	GRASEAL Packing - ML	6
2205-P	GRASEAL Packing - MP	6
2220	GRASEAL Packing - RP	9
2225	GRASEAL Packing - SP	9
2250-A	Low Torque Adapter Packing	7
2280-S	Super Seal Packing	8, 32
2660	Rubber Molded Packing with Cotton duck	30
2661	Rubber Molded Packing	30
2665	Slip Mold Packing	30
2670	Rubber O-Ring	31
2788-AF	AL-METAL Packing - AF	16, 27
2930	HIGH GUARD Packing	7
2940	Graphite Fiber Packing	16, 26
2996-NA	Plastic Graphite Packing - NA	16
8420	Round Braided Packing	34, 35
8420-BH	Round Braided Packing-BH	34, 35
8410-E	Round Braided Packing-E	34, 35
8420-G	Round Braided Packing with graphite treatment	34, 35
8420-H	Round Braided Packing-H	34, 35
8420-WH	Round Braided Packing-WH	34, 35
8520	Square Braided Packing	32, 33
8520-BH	Square Braided Packing-BH	32, 33
8510-E	Square Braided Packing-E	32, 33
8520-G	Square Braided Packing with graphite treatment	32, 33
8520-H	Square Braided Packing-H	32, 33
8520-WH	Square Braided Packing-WH	32, 33
9026	NAFLON PTFE Back-up Ring	31
9027	NAFLON PTFE Molded Packing	28
9033	NAFLON Fiber Packing - T	14, 21
9034	NAFLON Fiber Packing - T	14, 21
9036	NAFLON Fiber Packing (Soft)	20
9038	G-FLON Packing	19
9039	Oxidized PAN fiber Packing	25
9040	Aramid Fiber Packing	23
9040-W	Aramid Fiber Packing - White	24
9040-WR	Aramid Fiber Packing - White	24
9041	NAFLON Fiber Packing - G	14
9042	NAFLON Fiber Packing - G	14
9042-S	NAFLON Fiber Packing - G	18
9042-OX	NAFLON Fiber Packing - G	15, 18
9044	THERMALFLON Packing	12, 32
9077	NAFLON Carbon Fiber Packing	13
9077-L	NAFLON Carbon Fiber Packing - L	22
9079	NAFLON impregnated CT Packing	18, 32
9401	Fluorine Grease	36

Head Office

6-1, Hatchobori 1-chome, Chuo-ku, Tokyo 104-8555, Japan
International Marketing and Sales Group
 Phone: 81-3-4413-1132 Fax: 81-3-3552-6108
 Web Site: <https://www.nichias.co.jp/>

Overseas Sales Companies
Indonesia
PT. NICHIAS SUNIJAYA

Panin Life Center, 2nd Floor, Room 205, Jl. Letnan Jenderal S. Parman
 Kav. 91, Jakarta 11420, Indonesia
 Phone: +62-21-56956207 Fax: +62-21-56956208/56956209

Malaysia
NICHIAS SOUTHEAST ASIA SDN. BHD.

Suite A1102, 11th Floor, West Wing, Wisma Consplant 2,
 No. 7, Jalan SS 16/1, 47500 Subang Jaya, Selangor Darul Ehsan, Malaysia.
 Phone: +60-3-5636-4067 Fax: +60-3-5636-4078

Singapore
NICHIAS SINGAPORE PTE. LTD.

25 International Business Park, #01-15/17 German Centre,
 Singapore 609916
 Phone: +65-6571-0830/0838 Fax: +65-6265-7681

Vietnam
NICHIAS VIETNAM CO., LTD

Room 12-K, 12Floor, Center Building,
 Hapulico Complex No1 Nguyen Huy Tuong,
 Thanh Xuan Trung, Thanh Xuan, Hanoi, Vietnam
 Phone: + 84-4-3791-7194 Fax: + 84-4-3791-6203

Thailand
NICHIAS (THAILAND) CO., LTD.

85 Moo 1, Wellgrow Industrial Estate T. Homsin, A. Bangpakong
 Chachoengsao 24180, Thailand
 Phone: +66-38-570-600 Fax: +66-38-570-601

THAI NICHIAS INTERNATIONAL CO., LTD.

Unit 1107, 11th Floor, AIA Capital Center
 89 Ratchadaphisek Road, Dindaeng, Dindaeng, Bangkok 10400 Thailand
 Phone: +66-2-001-2060 Fax: +66-2-001-2062

China
NICHIAS (SHANGHAI) TRADING CO., LTD.

霓佳斯（上海）贸易有限公司
 Room 1701, THE PLACE, Tower A, No. 100 Zun Yi Road,
 Changning District, Shanghai, P.R.China Postcode 200051
 中国上海市长宁区遵义路100号虹桥南丰城A栋1701室 邮编200051
 Phone: +86-21-6236-1783 Fax: +86-21-6236-1781

NICHIAS (SHANGHAI) TRADING CO., LTD. Guangzhou Branch

霓佳斯（上海）贸易有限公司 广州分公司
 17F-G, Gold Sun Building, No.109 Tiyu West Road, Guangzhou,
 Guang Dong Province, 510620, P.R.China
 中国广东省广州市天河区体育西路109号高盛大厦17楼G室 邮编 510620
 Phone: +86-20-3879-1640 Fax: +86-20-3879-1647

NICHIAS (SHANGHAI) AUTOPARTS TRADING CO., LTD.

霓佳斯（上海）汽车零部件 贸易有限公司
 Room 1702, THE PLACE, Tower A, No. 100 Zun Yi Road,
 Changning District, Shanghai, P.R.China Postcode 200051
 中国上海市长宁区遵义路100号虹桥南丰城A栋1702室 邮编200051
 Phone: +86-21-6236-2668 Fax: +86-21-6236-2667

Germany
NICHIAS AUTOPARTS EUROPE GmbH

Prinzenallee 7, 40549 Düsseldorf, Germany
 Phone: +49 (0)211-52391-058 Fax: +49 (0)211-52391-200

Overseas Construction Companies
Malaysia
NICHIAS SOUTHEAST ASIA SDN. BHD.

Suite A1102, 11th Floor, West Wing, Wisma Consplant 2,
 No. 7, Jalan SS 16/1, 47500 Subang Jaya, Selangor Darul Ehsan, Malaysia.
 Phone: +60-3-5636-4067 Fax: +60-3-5636-4078

Thailand
THAI-NICHIAS ENGINEERING CO., LTD.

45 Huaypong-Nongbon Road, Huaypong, Muang Rayong,
 Rayong Province 21150, Thailand
 Phone: +66-38-682-242 Fax: +66-38-691-156

Overseas Factories
Indonesia
PT. NICHIAS ROCKWOOL INDONESIA
PT. NICHIAS METALWORKS INDONESIA
Malaysia
NICHIAS FGS SDN. BHD.
NT RUBBER-SEALS SDN. BHD.
Vietnam
NICHIAS HAIPHONG CO., LTD.
China
SUZHOU NICHIAS INDUSTRIAL PRODUCTS CO., LTD.

(苏州霓佳斯工业制品有限公司)

SUZHOU NICHIAS SEAL MATERIAL CO., LTD.

(苏州霓佳斯密封材料有限公司)

SHANGHAI XINGSHENG GASKET CO., LTD.

(上海兴盛密封垫有限公司)

SUZHOU SHUANGYOU AUTOPARTS CO., LTD.

(苏州双友汽车零部件有限公司)

India
NICHIAS INDUSTRIAL PRODUCTS PRIVATE LTD.
Czech
NICHIAS AUTOPARTS EUROPE a.s.
Mexico
NAX MFG, S.A.DE C.V.

Cautions

- The products included in this catalog are intended for common use, including those presented in the catalog. If you intend to use any of the products in a way that requires extremely high quality and reliability such that any possible defect may directly affect the safety of human lives, please make sure to consult with our company in advance and take necessary measures at your responsibility.
- Because the stated material values may vary according to actual usage environments or circumstances, please consider such figures as indications for reference.
- The content of the catalog explains the features of the products when they are used alone. When actually using the products, please start using them after testing them under the actual usage environment.
- The content of the explanation of the products may be modified without any advance notice, and the production of the product may also be discontinued without advance notice. Please obtain the latest version of the catalog, and confirm the content thereof. The date of issuance of this catalog is printed in the upper left corner of this page.
- The standards, accreditation and provisions of laws included in the catalog may not conform with the latest version thereof.
- We strictly prohibit any acts of infringement upon our rights that are protected by the Copyright Act with regard to information included in the catalog, through the production of copies or imitations, misappropriation or unauthorized reprinting.
- Please be informed that, in the case where any problem involving a third party's industrial property right arises due to the use of any product included in the catalog, our company shall not be responsible for any problems other than the problems arising strictly due to reasons related to only such products.
- Please be aware that our company will not bear any responsibility for the following damage related to our products:
 - Damage arising due to natural disasters or accidents occurring for reasons that are not attributable to our company;
 - Damage arising due to remodeling, repairing or other acts by a third party;
 - Damage arising due to the willful intent or negligence of the customer or the user, or due to the improper use or use under abnormal conditions of the products;
 - Damage arising due to the failure to carry out regular checkups and appropriate repairs, maintenance and part replacements, considering various conditions, such as the usage conditions, usage environment and usage period, etc., of the product;
 - Indirect damage (including any operational damage, lost profits, opportunity losses, etc.) arising due to the use of or inability to use our company's product;
 - Damage arising due to a situation which was unforeseeable under the technical standards at the time of the shipment of our company's product; or
 - Damage arising due to reasons that are not attributable to our company.